

als

airfield lighting systems

Big enough to cope,
small enough to care.



- ICAO • Annex 14 Volume I
- IEC • TS 61827
- EASA • CS-ADR-DSN
- AENA • DIN/DSEYN/PP 11/010
- FAAAC 150/5345-46
- DIN/DSEYN/PP/T/011
- EB No. 67

TECHNICAL DATA

Compliant with NATO, UK & US Military Specifications



als

12" LED Inset Lights

- AL/IN Approach Centre Line and Crossbar
- AS/IN Approach Side Row
 - TH/IN Runway Threshold
 - TW/IN Threshold Wing Bar
- THRE/IN Runway End/Threshold Runway End
- RB/IN Runway Edge

FEATURES

- Low protrusion of 6 mm above ground level
- Adaptable to all kinds of CCRs and ILCMS systems
- PWM digital regulation providing excellent consistency of chromaticity
- Integrated optical module with high light efficacy and good consistency
- Aluminum alloy forged top cover with hardened surface and corrosion resistance treatment
- Built-in surge protection
- Specially designed fail open system suitable for strong magnetism, vibration and other environments



MECHANICAL

- Mounting • 6 x M10 bolts
- Static Load Resistance • $\geq 35t$
- Dynamic Load Resistance • 40J
- Net Weight • 6.9kg
- Gross Weight • 7.2kg
- Packing Dimensions • 354mm (L) x 324mm (W) x 135mm (H)



ENVIRONMENTAL

- Operating Temperature • -55°C~+55°C
- Storage Temperature • -55°C~+85°C
- Protection Class • IP68
- Humidity • 0~100%



ELECTRICAL

- Connection • FAA L-823
- Rated Input Current • 6.6A
- Power Factor • >0.98
- Emission • IEC 61000-6-4
- Immunity • IEC 61000-6-2
- Service Life • LED useful lamp life >80000h
- Approach Centre Line and Crossbar • 60VA
- Approach Side Row • 30VA
- Runway End • 20VA
- Runway Threshold / Threshold Wing Bar • 35VA Runway
- Runway Threshold and End • 40VA (1P) • 35/20VA (2P)
- Edge-White/Red • 30VA (1P) • 23/14VA (2P) Runway
- Runway Edge-White/White • 45VA (1P) • 23/23VA (2P)
- Edge-White/Yellow • 40VA (1P) • 23/22VA (2P)
- Runway Edge-Yellow/Red • 28VA (1P) • 22/14VA (2P)

COMPONENTS

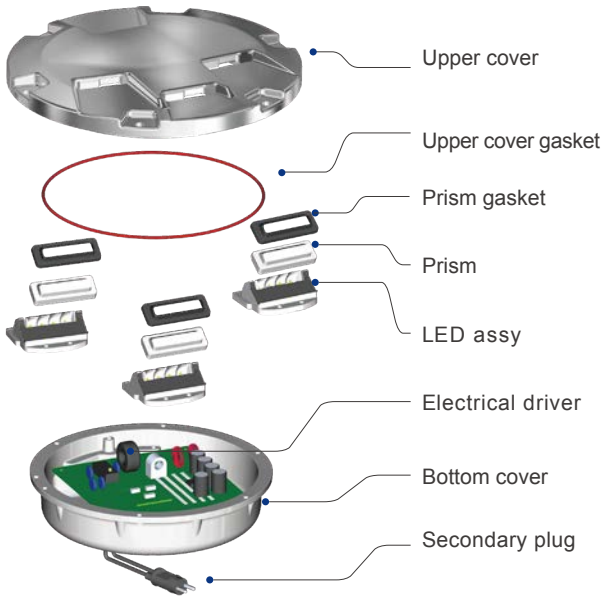

DIMENSIONS

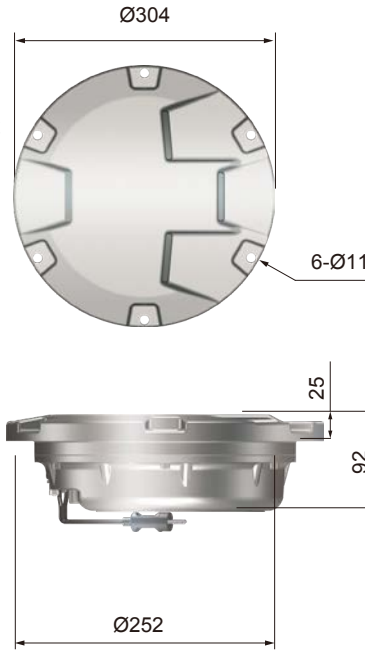

ACCESSORIES

- ⊙ 12 inches shallow base assy (bottom entry/side entry)
- ⊙ 12 inches deep base assy
- ⊙ L-823 receptacle
- ⊙ 12 inches light fixture handle

PHOTOMETRICS

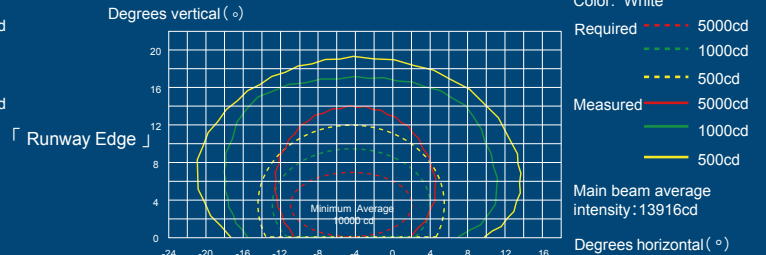
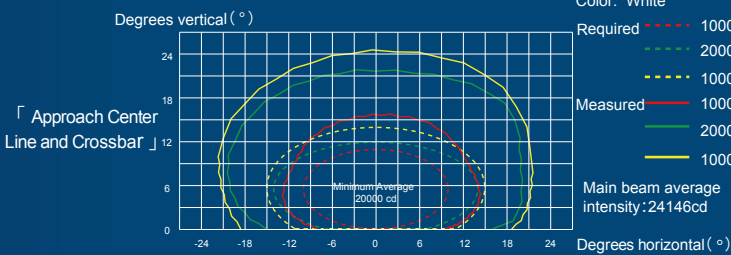

Airfield Lighting Systems UK Limited (Headquarters)

Head Office: Aviation House, Russell Gardens, Wickford, Essex, SS11 8BF

Tel: +44 1702 547562

ALS MENASA Trading FZCo

Address: JAFZA One Tower A - Floor 6 - Office 610 - Mina Jebel Ali - Jebel Ali Freezone - Dubai - United Arab Emirates

Tel: +44 1702 547562 ex 218

Website: www.airfieldlightingsystems.com
 Email: sales@airfieldlightingsystems.com

ORDERING CODES

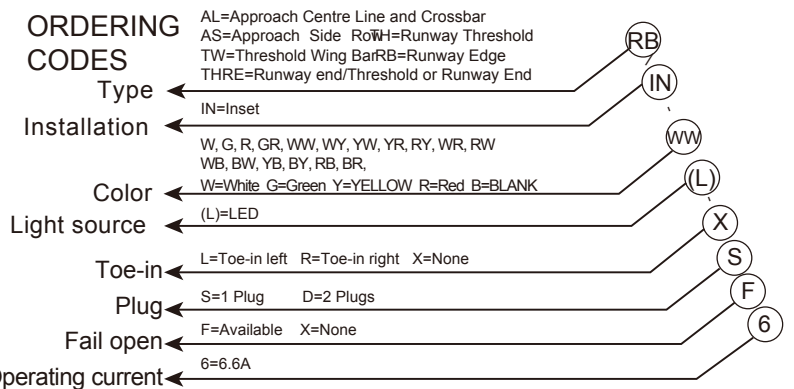

* Accessories should be ordered separately