

# als



airfield lighting systems

Big enough to cope,  
small enough to care.



## als

### 8" LED Inset Lights

- RC/IN Runway Centre Line
- TZ/IN Touchdown Zone
- FI/IN Rapid Exit Taxiway Indicator
- RE/IN Runway End Take-off and Hold Stopway

## FEATURES

- Low protrusion of 6 mm above ground level
- Adaptable to all kinds of CCRs and ILCMS systems
- PWM digital regulation providing excellent consistency of chromaticity
- Integrated optical module with high light efficacy and good consistency
- Aluminum alloy forged top cover with hardened surface and corrosion resistance treatment
- Built-in surge protection
- Specially designed fail open system suitable for strong magnetism, vibration and other environments



ICAO • Annex 14 Volume I EASA • CS-ADR-DSN

FAA • AC 150/5345-46 • EB No. 67

IEC • TS 61827

AENA • DIN/DSEYN/PPT/010  
DIN/DSEYN/PPT/012  
DIN/DSEYN/PPT/013

Compliant with NATO, UK & US Military Specifications

## TECHNICAL DATA



### MECHANICAL

Mounting • 2 x M10 bolts

Static Load Resistance •  $\geq 20t$

Dynamic Load Resistance • 40J

Net Weight • 3.5kg

Gross Weight • 3.7kg

Packing Dimensions • 253mm (L) x 223mm (W) x 107mm (H)



### ENVIRONMENTAL

Operating Temperature • -55°C~+55°C

Storage Temperature • -55°C~+85°C

Protection Class • IP68

Humidity • 0~100%



### ELECTRICAL

Connection • FAA L-823

Rated Input Current • 6.6A/2.2A

Power Factor • >0.98

Emission • IEC 61000-6-4

Immunity • IEC 61000-6-2

Service Life • LED useful lamp life > 80000h

Runway Centre Line -White/White • 20VA (1P) • 11/11VA (2P)

Runway Centre Line -White/Red • 17VA (1P) • 11/8VA (2P)

Runway Centre Line -White • 14VA

Runway Centre Line -Red • 11VA

Touchdown Zone • 14VA

Runway End • 13VA

Take-off and Hold • 13VA

Rapid Exit Taxiway Indicator • 15VA

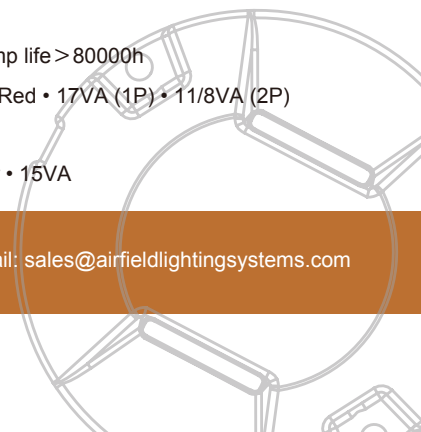



COMPONENTS

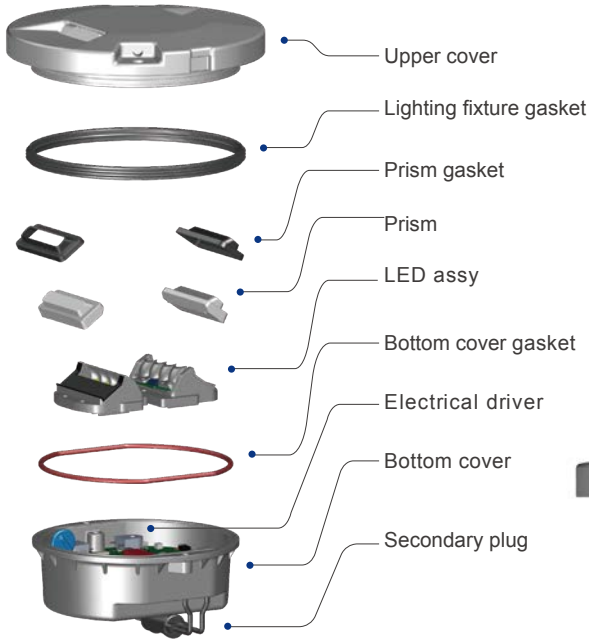

DIMENSION

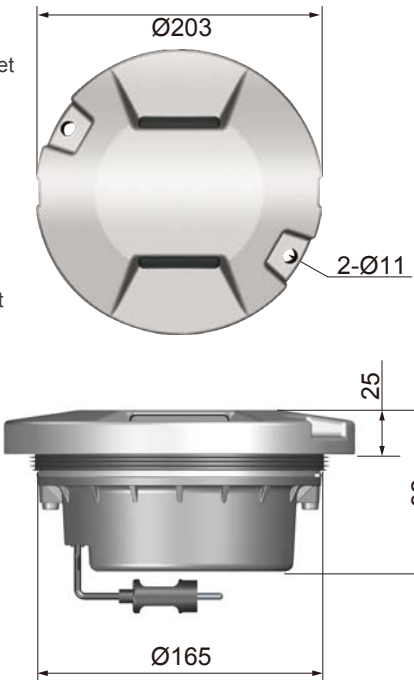

ACCESSORIES

- ◎ 8 inches shallow base assy (bottom entry/side entry)
- ◎ 12 inches shallow base assy (bottom entry/side entry)
- ◎ 12 inches deep base assy
- ◎ 8-12 inches adapter ring assy
- ◎ L-823 receptacle
- ◎ 8 inches light fixture handle

PHOTOMETRICS

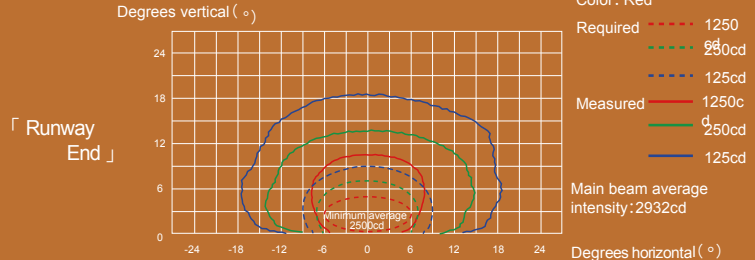
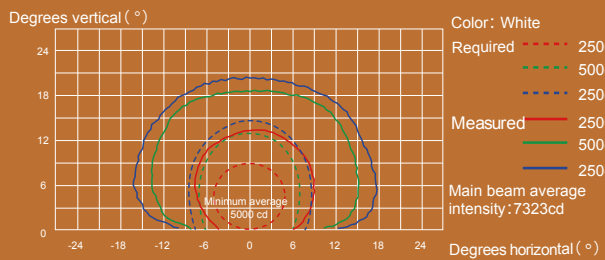

Airfield Lighting Systems UK Limited (Headquarters)

Head Office: Aviation House, Russell Gardens, Wickford, Essex, SS11 8BF

Tel: +44 1702 547562

ALS MENASA Trading FZCo

Address: JAFZA One Tower A - Floor 6 - Office 610 - Mina Jebel Ali - Jebel Ali Freezone - Dubai - United Arab Emirates

Tel: +44 1702 547562 ex 218

Website: www.airfieldlightingsystems.com  
Email: sales@airfieldlightingsystems.com

ORDERING CODES

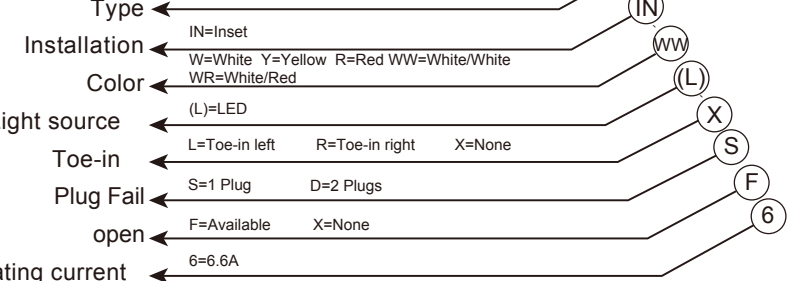

\* Accessories should be ordered separately