

# als

airfield lighting systems

Big enough to cope,  
small enough to care.



## als

### LED Unidirectional Elevated Lights

- AL/E Approach Centre Line and Crossbar
- AS/E Approach Side Row
- TH/E Runway Threshold
- TW/E Threshold Wing Bar
- RE/E Runway End
- SB/E Stop Bar  
No-entry Bar



ICAO • Annex 14 Volume I  
EASA • CS-ADR-DSN  
IEC • TS 61827

FAA • AC 150/5345-46  
• EB No. 67

AENA • DIN/DSEYN/PPT/015

Compliant with NATO, UK  
& US Military Specifications

### TECHNICAL DATA



#### MECHANICAL

Baseplate Mounting Holes • 3xØ12

Net Weight • 2.8kg

Gross Weight • 3.1kg

Packing Dimensions • 300mm (L) x 240mm (W) x 200mm (H)



#### ENVIRONMENTAL

Operating Temperature • - 55°C~+55°C

Storage Temperature • - 55°C~+85°C

Protection Class • IP67

Humidity • 0~100%



#### ELECTRICAL

Connection • FAA L-823

Rated Input Current • 6.6A

Power Factor • >0.98

Emission • IEC 61000-6-4

Immunity • IEC 61000-6-2

Service Life • LED useful lamp life > 80000h

Approach Centre Line and Crossbar • 31VA

Approach Side Row • 22VA

Runway Threshold • 27VA

Threshold Wing bar • 27VA

Runway End • 11VA

Stop Bar • 8VA

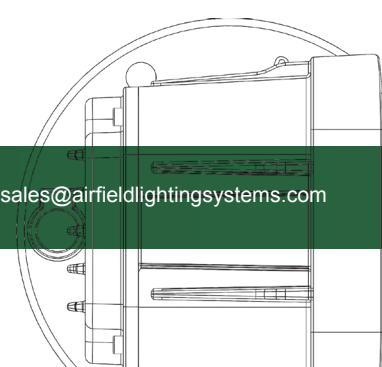



COMPONENTS

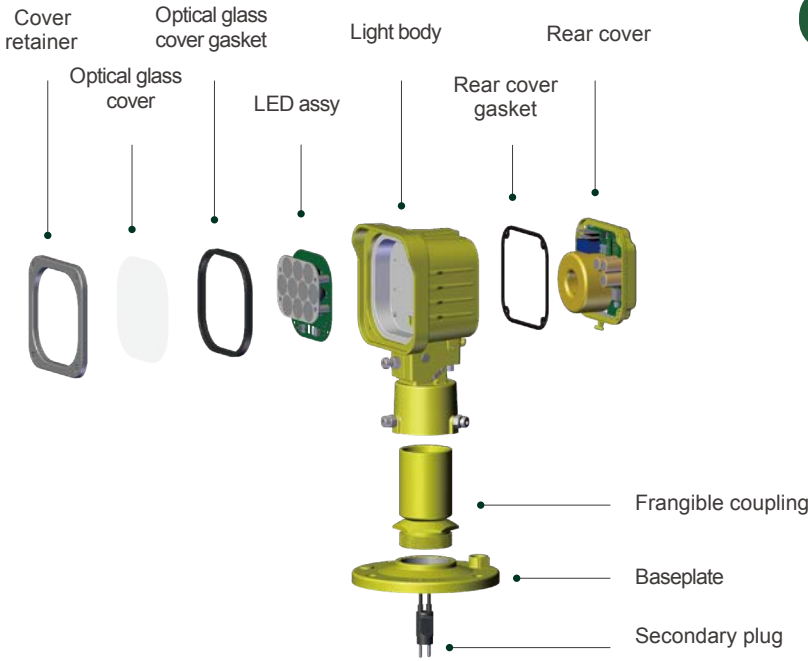

DIMENSION

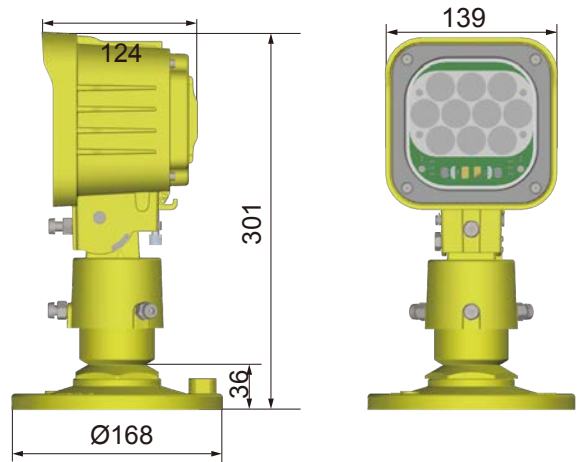

ACCESSORIES

- © Baseplate (168mm OD)
- © Baseplate (240mm OD)
- © Baseplate (300mm OD)
- © L-823 receptacle
- © 2 inches frangible coupling type A (pole mounted)
- © 2 inches frangible coupling type B (ground mounted)

PHOTOMETRICS

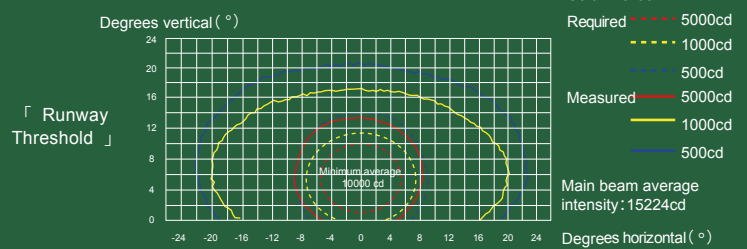
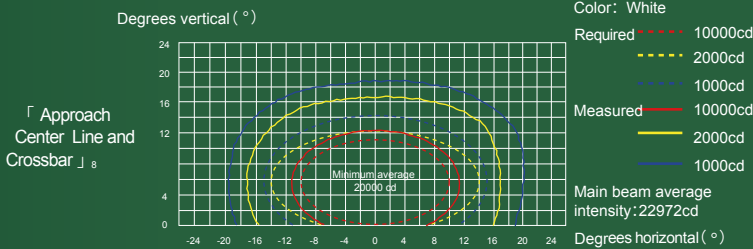

Airfield Lighting Systems UK Limited (Headquarters)

Head Office: Aviation House, Russell Gardens, Wickford, Essex, SS11 8BF

Tel: +44 1702 547562

ALS MENASA Trading FZCo

Address: JAFZA One Tower A - Floor 6 - Office 610 - Mina Jebel Ali - Jebel Ali Freezone - Dubai - United Arab Emirates

Tel: +44 1702 547562 ex 218

Website: www.airfieldlightingsystems.com  
Email: sales@airfieldlightingsystems.com

ORDERING CODES

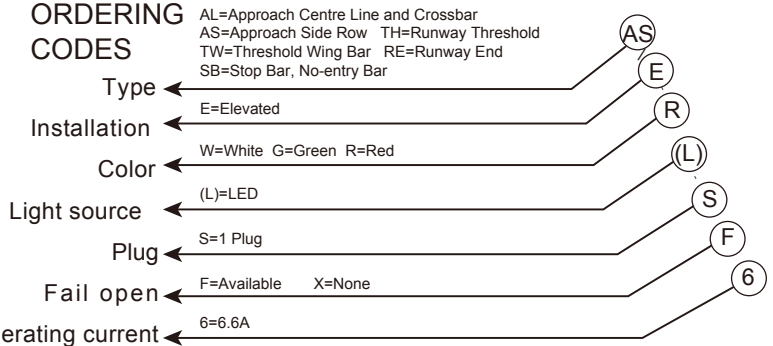

\* Accessories should be ordered separately