

als



airfield lighting systems

Big enough to cope,
small enough to care.



als



LED Bidirectional Elevated Lights

- RB/E-X Runway Edge
- RB/E-C Runway Edge
With Circling Guidance
- THRE/E Runway End/Threshold



ICAO • Annex 14 Volume I EASA •
CS-ADR-DSN

FAA • A C 150/5345-46
• EB NO.67

IEC • TS 61827

AENA • DIN/DSEYN/PPT/015
DIN/DSEYN/PPT/016

Compliant with NATO, UK
& US Military Specifications

TECHNICAL DATA



MECHANICAL

Baseplate Mounting Holes • 3xØ12

Net Weight • 4kg

Gross Weight • 4.2kg

Packing Dimensions • 240mm (L) x 240mm (W) x 240mm (H)



ENVIRONMENTAL

Operating Temperature • - 55°C~+55°C

Storage Temperature • - 55°C~+85°C

Protection Class • IP67

Humidity • 0~100%



ELECTRICAL

Connection • FAA L-823

Rated Input Current • 6.6A

Power Factor • >0.98

Emission • IEC 61000-6-4

Immunity • IEC 61000-6-2

Service Life • LED useful lamp life > 80000h

Runway Edge - White/White and White/Yellow • 40VA, Yellow/Red and White/Red • 30VA, White • 27VA, Yellow • 27VA, Red • 16VA Runway

Edge with Circling Guidance - White/White and White/Yellow • 41VA, Yellow/Red and White/Red • 34VA

Runway End/Threshold - Green/Red • 36VA, Green • 31VA





COMPONENTS

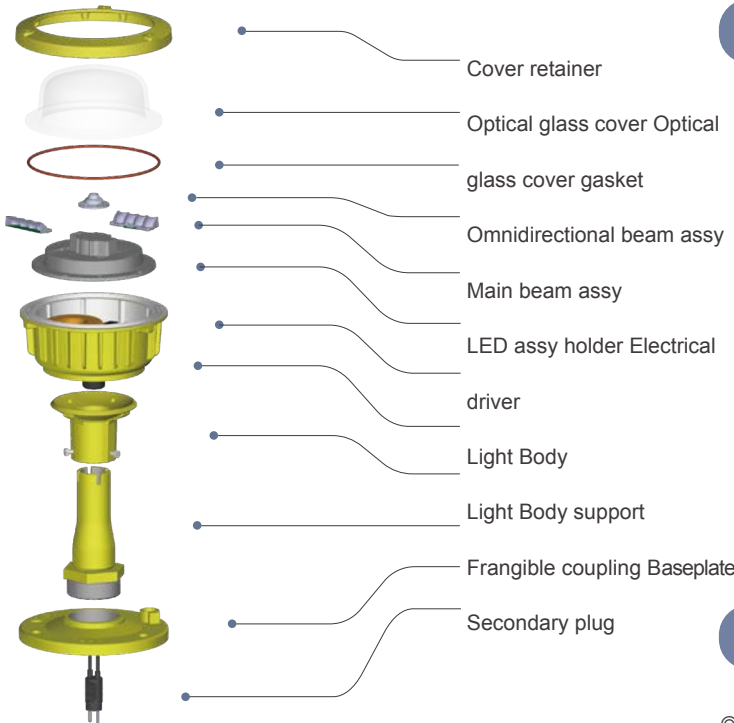

DIMENSIONS

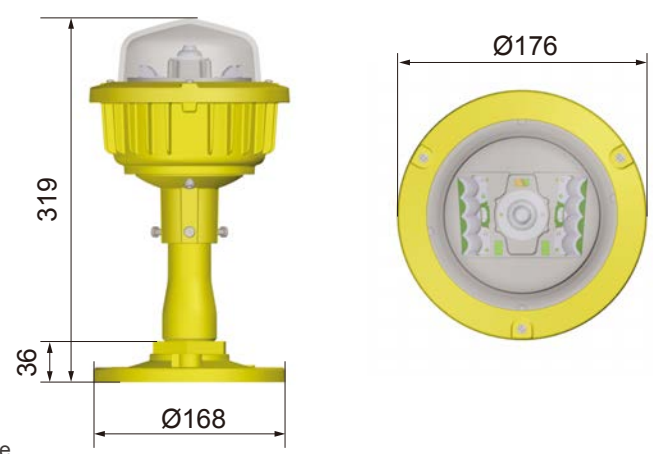

ACCESSORIES

- ◎ Baseplate (168mm OD)
- ◎ Baseplate (240mm OD)
- ◎ Baseplate (300mm OD)
- ◎ 2-1 inches frangible coupling
- ◎ L-823 receptacle

PHOTOMETRICS

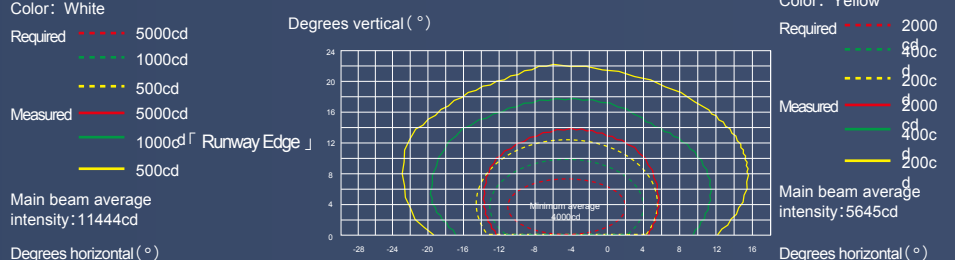
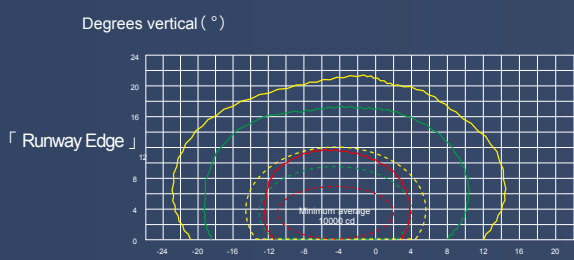

Airfield Lighting Systems UK Limited (Headquarters)

Head Office: Aviation House, Russell Gardens, Wickford, Essex, SS11 8BF

Tel: +44 1702 547562

ALS MENASA Trading FZCo

Address: JAFZA One Tower A - Floor 6 - Office 610 - Mina Jebel Ali - Jebel Ali Freezone - Dubai - United Arab Emirates

Tel: +44 1702 547562 ex 218

Website: www.airfieldlightingsystems.com
Email: sales@airfieldlightingsystems.com

ORDERING CODES

